

# Smart Trash Bin for Management

by Turnitin

---

**Submission date:** 27-Jun-2022 06:57PM (UTC+0700)

**Submission ID:** 2110992382

**File name:** Smart\_Trash\_Bin\_for\_Management.pdf (420.85K)

**Word count:** 3106

**Character count:** 16019

## SMART TRASH BIN FOR MANAGEMENT OF GARBAGE PROBLEM IN SOCIETY

Aldiga Rienarti Abidin<sup>1</sup>, Yuda Irawan<sup>2\*</sup>, Yesica Devis<sup>3</sup>

Universitas Hang Tuah Pekanbaru<sup>1,2,3</sup>

yudairawan89@gmail.com

10

Received : 15 August 2022, Revised: 29 September 2022, Accepted : 29 September 2022

\*Corresponding Author

### ABSTRACT

Along with the times, one of the environmental problems faced today is the waste problem. Every day humans will produce waste both industrial waste and household waste in everyday life. Garbage will become an environmental problem because it can interfere with human health, cause bad smells and even air pollution. Poor waste management causes harmful and unhealthy environmental problems. Sometimes people are reluctant when they want to dispose of garbage by opening and closing the trash can so it is feared that they will get bacteria on their hands. The problem of environmental waste can arise from waste management that unites all types of organic and inorganic waste in the same place, making it difficult to recycle waste. Another problem is that sometimes the cleaners are negligent in emptying the full trash can, so it will cause a bad smell. Based on the above problems, it is necessary to make a smart trash bin which will later be able to sort out the types of organic and inorganic waste. The lid of the trash can will open automatically when someone wants to throw out the trash and it will close automatically when it's finished taking out the trash. With the waste sorting technology, it will automatically reduce environmental pollution by waste, and facilitate waste management so that it can be recycled again. To overcome the bins that are full for too long, if the trash is full, it will automatically notify the cleaners via Telegram messages. From the test results, it can be concluded that the ultrasonic sensor can detect if someone is approaching with a maximum distance of 50 cm so that the cover can be opened automatically for 7 seconds. The servo motor can rotate the waste sorter according to the type of organic or inorganic waste based on the detection results of the capacitive proximity sensor. The telegram message has been successfully sent if the garbage condition has been fully detected through the ultrasonic sensor. LCD can display the type of organic or inorganic waste accurately.

**Keywords:** Microcontroller, Arduino, ultrasonic, Capacitive Proximity Sensor, Smart Trash Bin.

1

### 1. Introduction

Garbage is one of the serious problems in environmental issues (Dadang Haryanto, 2019). Every day humans will produce waste, both industrial waste and household waste in everyday life. Garbage will become an environmental problem because it can interfere with human health, cause bad smells and even air pollution (Sukarjadi et al., 2017). People who always think positively will think about the consequences of throwing garbage carelessly, while lazy people will not think about the impact on the environment such as disease, which can attack at any time (Handoyo et al., n.d.).

Waste management in a way that violates the law and intentionally conducts waste management activities without paying attention to norms, standards, procedures, or criteria that can cause environmental pollution (Ma'arif et al., 2019). It is proven by the existence of Law No. 18 of 2008 concerning Waste Management (Fikri et al., 2021). For perpetrators of waste crimes that affect public health, security, environmental pollution, and/or damage the environment, they are threatened with a minimum imprisonment of 4 (four) years and a maximum of 10 (ten) years and a minimum fine of Rp. 100,000,000 (One hundred million rupiah) and a maximum of Rp. 5,000,000,000 (Five billion rupiah) (Indonesia PR, 2018).

Poor waste management causes harmful and unhealthy environmental problems (SARI, 2021). The trash can that has been provided by the janitor is only a display that is poorly maintained and its utilization is not optimal because the concept is not attractive (Sukarjadi et al., 2017). Using the manual way of opening and closing the lid of the trash can causes people to feel reluctant to throw garbage in its place (ALAM, 2012), because it can cause hands prone to bacteria from the trash can (Herliza & Almasri, 2022) (Yadav et al., 2021).

In addition, many people still dispose of waste that is not in accordance with the type of waste, namely determining the type of organic or inorganic waste (Bere et al., 2021). In Law number 18 of 2008 concerning waste management, it is stated that the definition of waste is the remnants of the results of human activities. Based on its nature, waste is divided into two types, namely organic and inorganic waste (Yunus, 2018). Improper waste management will have an impact on the environment, cause odors, and spread diseases (Wuryanto et al., 2019). The environmental problems can arise from waste management that unites all types of waste in the same place (Ismail et al., 2021). Another problem is that sometimes the cleaners are negligent in emptying the full trash can, so it will cause a bad smell (Melvin et al., n.d.) (Yahya, 2018).

Based on the above problems, the researchers made a study, namely the creation of smart trash bins which later on the trash can sort out waste by type, namely organic and inorganic. With the automatic waste sorting technology based on the type of waste, it is hoped that it will reduce environmental pollution by waste, and facilitate waste management so that it can be recycled again. The lid of the trash can will open automatically when someone wants to throw out the trash and it will close automatically when it's finished taking out the trash. To overcome the bins that are full for too long, if the trash is full, it will automatically notify the cleaners via Telegram messages.

As for several previous studies that discussed smart trash bins, one of which was a study conducted by Egi Suandi entitled Trash Can Information System With Web-Based Monitoring and Whatsapp Assisted by Arduino Mega 2560. The result of this research is a trash can that will display notification via the website and whatsapp when the trash can is full (Egi Suandi<sup>1</sup>, Ritzkal<sup>2</sup>, 2018).

Another research has been carried out by Haryanto entitled Trash Can Opens and Closes Automatically Using Arduino Uno Based Infrared Sensors. The results of this study are a unique and interesting trash can that can open and close automatically if someone approaches to throw garbage (Dadang Haryanto, 2019).

Based on the summary of previous research, the researcher will create a smart trash bin (Smart Trash Bin) by developing technology from previous researchers, namely a trash can equipped with an automatic opener and closing if someone is going to throw out the trash, then the trash bin will sort out the trash automatically. based on the type of organic or inorganic waste, the trash can emits a sound and lights up the LED. If the trash can is full, the system will automatically warn the cleaning staff via SMS message so that the officer will quickly deal with the problem of the full bin.

## 2. Research Methods

In this stage the researcher uses the waterfall method, because this method is a method that is widely used by system development (Yuda Irawan, 2020) (Yusril & Setyawan, 2015).

### 1. Requirements Definition

At this stage the researcher collects data at the landfill, then analyzes the needs that will be used in building smart trash bins, namely:

- a. Arduino uno R3, ultrasonic sensor, proximity sensor, buzzer, and LED, servo motor, as a tool to make a smart trash can (Yusa et al., 2021).
- b. Computers / Laptops are used as a medium to carry out the programming process on the device.

### 2. System and Software Design

In this stage, the researcher describes the design of the system to be built according to the analysis carried out, namely making smart trash bins that can open and close automatically, provide notification of trash bin capacity, and select types of organic and inorganic waste (Purwaningsih & Pebralia, 2022) (Sanjaya, H., Daulay, N. K., Trianto, J., & Andri, 2022). The models used are use cases, flowcharts and block diagrams used to design program logic (Irawan et al., 2021).

### 3. Implementation and Unit Testing

Program code creation is done using Arduino IDE software with C++ programming language which is used to process data and information from analysis and design results (Yunus, 2018).

### 4. Integration and System Testing

Testing of the system that has been completed is needed to find out whether there are still errors in the logic design or program, if there are still errors, improvements will be made so that the program that has been built is ready and feasible to use (Hidayat & Syahrani, 2017) (Sohor et al., 2020).

### 5. Operation and Maintenance

At this stage the program that has been completed in accordance with the system design, will be applied to the agency in need. This stage has resulted in a system that can run optimally (Solihati et al., 2020). The system that has been run must be maintained. Maintenance also includes fixing errors that could not be found in the previous stage (Irawan & Wahyuni, 2021).

### 3. Results and Discussions

In general, in designing the Smart Trash Bin, several technology components are used, namely Arduino Uno, Servo Motor, LED Buzzer, Ultrasonic HC-SRF04 and Capacitive Proximity Sensor. The block circuit diagram can be seen in Figure 1:

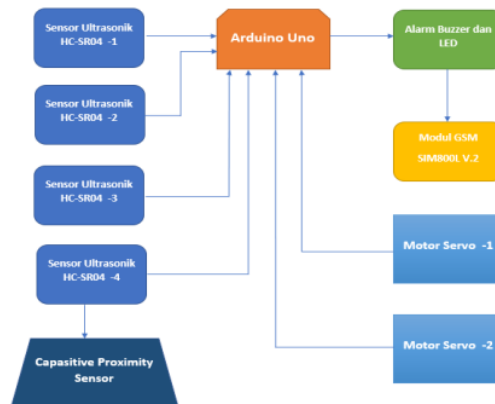

Fig 1. Block Circuit Diagram

Information:

1. Arduino Uno is a device that manages all components of the smart trash can.
2. Ultrasonic Sensor HC-SRF04 -1 serves to detect movement when people are going to throw garbage.
3. Ultrasonic Sensor HC-SRF04 -2 serves to detect organic waste bins when they are full.
4. Ultrasonic Sensor HC-SRF04 -3 functions to detect inorganic types of trash bins when they are full.
5. Ultrasonic Sensor HC-SRF04 -4 serves to assist the proximity sensor to sort out the types of organic or inorganic waste, and drive the servo motor.
6. GSM module to send messages via SMS when the trash is full.
7. Buzzer and LED function to emit sound and light.

While the circuit schematic of this tool can be seen in the image below:

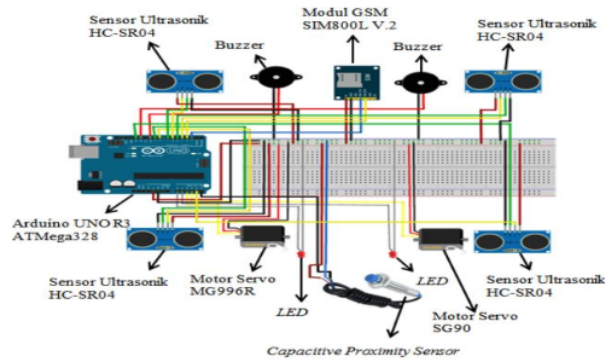

Fig 2. Schematic of the Smart Trash Bin Circuit

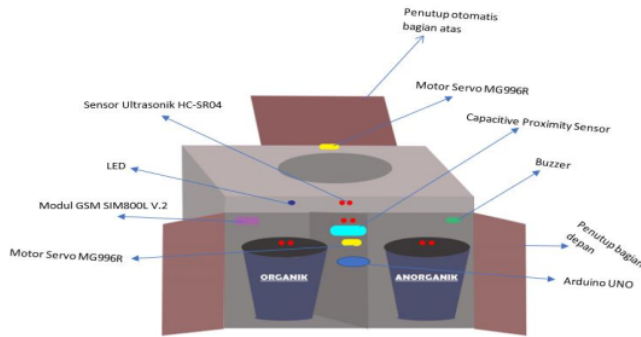

Fig 3. Smart Trash Bin Prototype Design

**Tool description:**

When someone throws garbage, the ultrasonic sensor 1 will be active and detect the movement of objects or people at a distance of 40 cm, the servo motor will work to open the cover of the trash can. Then the proximity sensor detects the type of waste that is entered, whether it is organic or inorganic, there will be 2 bins of organic and inorganic waste. Ultrasonic sensors 2 and 3 will detect when the volume of waste is full, the buzzer will sound an alarm and the LED will turn red when the garbage is full and the system will send an SMS notification to the cleaners.

**7 Implementation of Smart Trash Can Design Using Proximity Sensor Based on Arduino Microcontroller**



Fig 4. The Front of the Implementation of the Smart Trash

Figure 4 describes the front of the smart trash can which has two doors for organic and inorganic waste bins, and above the door there is an ultrasonic sensor that detects the presence of



humans with a maximum distance of 50 cm, the LED will light up according to the type of organic or inorganic waste. The top of the smart trash can with one lid of the trash can and will open automatically when the ultrasonic sensor detects human distance, the servo will open the lid of the trash can.

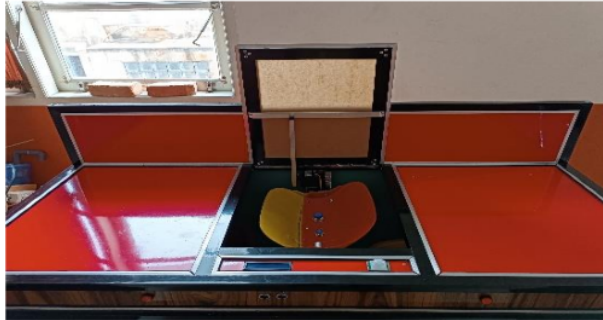

Fig 5. Inside the Top of the Smart Trash

Figure 5 is the inside of the smart trash can that can sort out the types of organic and inorganic waste using a capacitive proximity sensor, if the sensor detects organic waste, the servo will move to the left, and if no organic waste is detected, the servo will move to the right.



Fig 6. Inside the Implementation of the Smart Trash

Figure 6 is the inside of a smart trash can that has two trash bins, namely an organic trash can and an inorganic trash can, and inside each trash can there is an ultrasonic sensor that detects the full capacity of the trash can.

#### 4. Conclusion

From testing on expert systems for diagnosing diseases in infants, it can be concluded that the system can produce conclusions according to the manual calculation, namely measles with a CF value of 100% or 1. Based on testing results made in accordance with the knowledge base obtained from pediatric disease experts. Users can see the results of the diagnosis and how to treat it. Based on the manual calculation of the program with the system, the certainty factor method is able to provide results based on the weight of the symptoms that have been selected by the user on the system and can provide answers in cases where the truth is not certain as in this study, namely diagnosing children's diseases.

#### Acknowledgement

The authors would like to thank Kementerian Pendidikan, Kebudayaan, Riset, dan Teknologi which has provided financial assistance related to this research, and thanks also

to the academic community of Hang Tuah University Pekanbaru who have always supported in conducting this novice lecturer research

### References

- ALAM, M. S. (2012). *Tempat Sampah Otomatis Berbasis Mikrokontroler ATmega8535*. 9(2), 451–455. <https://doi.org/10.30865/jurikom.v9i2.4058>
- Bere, S. H., Mahmudi, A., Sasmito, A. P., & Industri, F. T. (2021). *RANCANG BANGUN ALAT PEMBUKA DAN PENUTUP TONG SAMPAH OTOMATIS MENGGUNAKAN SENSOR JARAK BERBASIS ARDUINO*. 5(1), 357–363.
- Dadang Haryanto, R. I. W. (2019). Tempat Sampah Membuka Dan Menutup Otomatis Menggunakan Sensor Inframerah Berbasis Arduino Uno. *Jumantaka*, 03(1), 1. <http://jurnal.stmik-dci.ac.id/index.php/jumantaka/article/view/364>
- Egi Suandi<sup>1</sup>, Ritzkal<sup>2</sup>, A. H. H. (2018). Sistem Informasi Tempat Sampah Dengan Monitoring Berbasis Web Dan Whatsapp Berbantuan Arduino Mega 2560. *Semnati*, 217–223.
- Fikri, M., Hartama, D., & Kirana, I. (2021). Tempat sampah pintar berbasis sensor HC-SR04 menggunakan Aduino Uno R3. *J-SAKTI (Jurnal Sains Komputer & Informatika)*, 5(September), 666–676.
- Handoyo, A., Prasetyo, M. T., & Saptadi, A. H. (n.d.). *Rancang Bangun Alat Tempat Sampah Pintar Portable Berbasis Arduino Building Design of Arduino-Based Portable Smart Trash Bin Tool Universitas Muhammadiyah Semarang, Semarang untuk portible karena masih mengandalkan arus AC sehingga harus terpancang oleh*. 985–994.
- Herliza, S., & Almasri. (2022). Rancang Bangun Tempat Sampah Pintar sebagai Media Pembelajaran Sekolah. *Jurnal Pendidikan Tambusai*, 6(1), 2984–2995.
- Hidayat, C. R., & Syahrani, F. D. (2017). Perancangan Sistem Kontrol Arduino Pada Tempat Sampah Menggunakan Sensor Pir Dan Sensor Ultrasonik. *Jurnal Voice of Informatics*, 6, 65–75. <https://voi.stmik-tasikmalaya.ac.id/index.php/voi/article/view/82>
- Irawan, Y., Febriani, A., Wahyuni, R., & Devis, Y. (2021). Water quality measurement and filtering tools using Arduino Uno, PH sensor and TDS meter sensor. *Journal of Robotics and Control (JRC)*, 2(5), 357–362. <https://doi.org/10.18196/jrc.25107>
- Irawan, Y., & Wahyuni, R. (2021). Electronic Equipment Control System for Households by using Android Based on IoT ( Internet of Things ). *Journal of Physics: Conference Series*, 1783(1), 012094. <https://doi.org/10.1088/1742-6596/1783/1/012094>
- Ismail, M., Abdullah, R. K., & Abdussamad, S. (2021). Tempat Sampah Pintar Berbasis Internet of Things (IoT) Dengan Sistem Teknologi Informasi. *Jambura Journal of Electrical and Electronics Engineering*, 3(1), 7–12. <https://doi.org/10.37905/jjee.v3i1.8099>
- Ma'arif, R. A., Fauziah, & Hayati, N. (2019). Sistem Monitoring Tempat Sampah Pintar Secara Real-time Menggunakan Metode Fuzzy Logic Berbasis IOT. *Jurnal Infomedia*, 4(2), 69–74. <http://e-jurnal.pnl.ac.id/index.php/infomedia/article/view/1571>
- Melvin, J., Nitte, R., Manafe, Y. Y., & Ray, F. F. G. (n.d.). *Rancang Bangun Tempat Sampah Pintar Berbasis Arduino Uno Menggunakan Modul GSM*. 5(1), 44–50.
- Purwaningsih, S., & Pebralia, J. (2022). *PENGEMBANGAN TEMPAT SAMPAH PINTAR MENGGUNAKAN SENSOR ULTRASONIK BERBASIS ARDUINO UNO UNTUK LIMBAH MASKER*. 5(1), 1–6.
- Sanjaya, H., Daulay, N. K., Trianto, J., & Andri, R. (2022). Tempat Sampah Otomatis Berbasis Mikrokontroler Arduino. *Jurnal Riset Komputer*, 1(2), 51–54.
- SARI, W. (2021). Rancang Bangun Tong Sampah Pintar Berbasis Arduino Untuk Mendukung Program Peradaban Bersih Di Universitas Pembangunan Panca Budi Medan. *Kumpulan Karya Ilmiah Mahasiswa Fakultas Sains* .... <http://jurnal.pancabudi.ac.id/index.php/fastek/article/download/1774/1615>
- Sohor, S., Mardeni, Irawan, Y., & Sugjati. (2020). Rancang Bangun Tempat Sampah Otomatis Menggunakan Mikrokontroler Dan Sensor Ultrasonik Dengan Notifikasi Telegram. *Jurnal Ilmu Komputer*, 9(2), 154–160. <https://doi.org/10.33060/jik/2020/vol9.iss2.182>
- Solihati, T. I., Nuraida, I., & Hidayanti, N. (2020). Pemanfaatan Kardus Menjadi Tempat Sampah Pintar Berbasis Arduino UNO R3. *ABDIMAS: Jurnal Pengabdian Masyarakat*, 3(2), 342–

350. <https://doi.org/10.35568/abdimas.v3i2.962>
- Sukarjadi, S., Arifiyanto, A., Setiawan, D. T., & Hatta, M. (2017). Perancangan Dan Pembuatan Smart Trash Bin Di Universitas Maarif Hasyim Latif. *Teknika: Engineering and Sains Journal*, 1(2), 101. <https://doi.org/10.51804/tesj.v1i2.123.101-110>
- Wuryanto, A., Hidayatun, N., Rosmiati, M., & Maysaroh, Y. (2019). Perancangan Sistem Tempat Sampah Pintar Dengan Sensor HCRSF04 Berbasis Arduino UNO R3. *Paradigma - Jurnal Komputer Dan Informatika*, 21(1), 55–60. <https://doi.org/10.31294/p.v21i1.4998>
- Yadav, S., Raghuvanshi, R., Soni, G., Bangali, L., & Bundela, S. S. (2021). Global system for mobile communication (GSM) monitoring in industries using arduino uno. *IOP Conference Series: Materials Science and Engineering*, 1136(1), 012019. <https://doi.org/10.1088/1757-899x/1136/1/012019>
- Yahya, R. (2018). *Purwarupa Kotak Sampah Pintar Berbasis IoT (Internet Of Things)*. Agustus, 1–15.
- Yuda Irawan. (2020). Decision Support System For Employee Bonus Determination With Web-Based Simple Additive Weighting (SAW) Method In PT. Mayatama Solusindo. *Journal of Applied Engineering and Technological Science (JAETS)*, 2(1), 7–13. <https://doi.org/10.37385/jaets.v2i1.162>
- Yunus, M. (2018). Rancang Bangun Prototipe Tempat Sampah Pintar Pemilah Sampah Organik Dan Anorganik Menggunakan Arduino. *Proceeding STIMA*, 1(1), 340–343.
- Yusa, M., Santoso, J. D., & Sanjaya, A. (2021). Implementasi Dan Perancangan Pengukur Tinggi Badan Menggunakan Sensor Ultrasonik. *Pseudocode*, 8(1), 90–97. <https://doi.org/10.33369/pseudocode.8.1.90-97>
- Yusril, M., & Setyawan, H. (2015). Prototipe Smart Trash Bin Berbasis Tcp/Ip. *Competitive*, 10(1), 2010491. <https://ejurnal.poltekpos.ac.id/index.php/competitive/article/view/267>



# Smart Trash Bin for Management

## ORIGINALITY REPORT

14%

SIMILARITY INDEX

12%

INTERNET SOURCES

6%

PUBLICATIONS

%

STUDENT PAPERS

## PRIMARY SOURCES

1	<a href="http://digilib.uin-suka.ac.id">digilib.uin-suka.ac.id</a> Internet Source	2%
2	<a href="http://lifescienceglobal.com">lifescienceglobal.com</a> Internet Source	2%
3	<a href="http://ejournal.bsi.ac.id">ejournal.bsi.ac.id</a> Internet Source	1%
4	<a href="http://www.jurnal-umbuton.ac.id">www.jurnal-umbuton.ac.id</a> Internet Source	1%
5	<a href="http://journal.itny.ac.id">journal.itny.ac.id</a> Internet Source	1%
6	<a href="http://e-journal.ikhac.ac.id">e-journal.ikhac.ac.id</a> Internet Source	1%
7	<a href="http://repository.unika.ac.id">repository.unika.ac.id</a> Internet Source	1%
8	<a href="http://spel3.upm.edu.my">spel3.upm.edu.my</a> Internet Source	1%
9	<a href="http://jurnal.arkainstitute.co.id">jurnal.arkainstitute.co.id</a> Internet Source	1%

10	<a href="http://www.mdpi.com">www.mdpi.com</a> Internet Source	1 %
11	<a href="http://iopscience.iop.org">iopscience.iop.org</a> Internet Source	<1 %
12	<a href="http://repository.uin-suska.ac.id">repository.uin-suska.ac.id</a> Internet Source	<1 %
13	Yuda Irawan, Refni Wahyuni. "Electronic Equipment Control System for Households by using Android Based on IoT (Internet of Things)", <i>Journal of Physics: Conference Series</i> , 2021 Publication	<1 %
14	Eko Prayetno, Anton Hekso Yuniyanto, Indah Fatiroh, Rayandra Asyhar. "Perancangan Alat Penghisap dan Pengangkat Sampah pada Permukaan Laut Berbasis Mikrokontroler", <i>Jurnal Sustainable: Jurnal Hasil Penelitian dan Industri Terapan</i> , 2020 Publication	<1 %
15	Hetty Ismainar, Rika Melyanti, Yulisman, Suandi Daulay, Yuda Irawan, Rian Ordila. "Management Information System for Lancang Kuning Hospital Dompot Dhuafa Pekanbaru Using Codeigniter Framework", <i>Journal of Physics: Conference Series</i> , 2021 Publication	<1 %

16

I Gusti Ayu Agung Mas Aristamy, I Gede Iwan Sudipa, Christina Purnama Yanti, Indra Pratistha, Valentino Devi Waas. "An Application of a Decision Support System for Senior High School Scholarship with Modified MADM Method", 2021 6th International Conference on New Media Studies (CONMEDIA), 2021

Publication

<1 %

17

[eprosiding.ars.ac.id](http://eprosiding.ars.ac.id)

Internet Source

<1 %

18

[sim.ihdn.ac.id](http://sim.ihdn.ac.id)

Internet Source

<1 %

Exclude quotes Off

Exclude matches Off

Exclude bibliography On