

# Turnitin

*by* Yuda Irawan

---

**Submission date:** 03-Jun-2021 12:38PM (UTC+0700)

**Submission ID:** 1599474409

**File name:** IJETT-V69I4P208.pdf (771.7K)

**Word count:** 4877

**Character count:** 24943

# Intelligent Quality Control of Shrimp Aquaculture Based On Real-Time System and IoT Using Mobile Device

Yuda Irawan<sup>1\*</sup>, Hendry Fonda<sup>2</sup>, Eka Sabna<sup>3</sup>, Anita Febriani<sup>4</sup>

<sup>1,2</sup>Department of Information System, STMIK Hang Tuah Pekanbaru, Pekanbaru, Indonesia  
<sup>3,4</sup>Department of Computer Science, STMIK Hang Tuah Pekanbaru, Pekanbaru, Indonesia

<sup>1</sup>yudairawan89@gmail.com\*, <sup>2</sup>fondaanda@gmail.com, <sup>3</sup>es3jelita@yahoo.com,

**Abstract** - This research consists of monitoring the pH of the water, monitoring the flow of currents, and monitoring the temperature. This monitoring is very important because it affects the growth and success of cultivating shrimp. In this case, the pH of the water must be kept from 7.5 to 8.5. temperature also affects water quality so that the optimal water temperature for shrimp farming is 28 ° - 30 ° C. and the speed of water flow that must be maintained is 3.1 m / s to 3.6 m / s. Internet of Things (IoT) is a concept that can exchange various sources of information, interact with objects around us through an internet connection that can be controlled remotely. Tools in the form of a water pH sensor PH-4502C, a water flow sensor for water flow, and a DS18B20 temperature sensor that is connected to the ESP32 Module. The results of this study from the sensor measurement data compared with the results of the measuring device on the pH sensor of the water have an error percentage of 0.42%, the temperature sensor has an error percentage of 2.80%, while the current sensor has an error percentage of 3.22%. The average obtained on the water pH sensor is 7.8, the current sensor is 3.3 m / s, and the temperature sensor is 2.8 C °.

**Keywords** – Internet of Things (IoT), water pH PH-4502C, Water flow sensor, temperature sensor DS18B20, Mobile

## I. INTRODUCTION

Monitoring water pH, monitoring water flow, and monitoring temperature in shrimp ponds are very important because they affect the growth and success of shrimp farming [1]. The acidity level of pond water can affect shrimp growth. Even an extreme degree of acidity (pH) can kill shrimp[2],[3]. In this case, the pH of the water must be kept from 7.5 to 8.5[4]. When a decrease in pH occurs, lime will be sprinkled so that the pH conditions of the water return to normal [5],[6]. Then the temperature also affects water quality so that the optimal water temperature for shrimp farming is 28 ° - 30 ° C[7],[8]. In the flow of water that is driven by using a windmill to move the water flow so that the speed of the flow must be normal and not reduced[9],[10], the speed of the water flow that must be

maintained is 3.1 m / s to 3.6 m / s so that in conditions the flow rate of the pool must be maintained because it is very much needed in shrimp growth and shrimp resistance [11],[12],[13]. The manual system carried out by shrimp farmers must always monitor the pH of the water so that it is normal, so it takes a lot of time, temperature monitoring is rarely known so that it makes water conditions abnormal[14],[15] and also monitoring the flow of water still carries out manual monitoring, of course, this is a lot of loss in terms of time and efficiency[16],[17]. in shrimp farming so that delays in handling in the event of water pH, decreasing or excessive temperature and irregular currents result in failure in shrimp farming[18].

To overcome this problem, a monitoring system is needed which aims to determine the pH of the water, water flow, and temperature without having to come directly to the shrimp farms[19]. Internet of Things (IoT) is a concept that can exchange various sources of information, interact with objects around us through an internet connection that can be controlled remotely[20]. Tools in the form of a water pH sensor PH-4502C, a Water flow sensor for water currents, and the DS18B20 temperature sensor, which is connected to the ESP32 Module. ESP32 is a microcontroller introduced by ESPres Systems, which is the successor of the ESP8266 Microcontroller [21]. In this microcontroller, there is already a WiFi Module on the chip, so that it is very supportive for creating an Internet of Things application system. When the pH sensor of water PH-4502C reads with a measurement of 7.5 to 8.5 in a shrimp pond, the ESP32 will send data on the pH reading of the water to the drop then will be displayed to the android application to see the results of the monitoring data then the user will receive a notification in the android application when the water pH exceeds 8.5, also if it occurs less than 7.5[22]. When the DS18B20 temperature sensor detects high ambient temperature conditions, it can be ascertained that it affects the pH of the water in the pond and when the water flow sensor reads water flow with 3.1 m / s to 3.6 m / s, ESP32 will send data from the Water flow sensor to the database then will be displayed to the android application to see the monitoring results, the user will receive



a notification in the android application if the water flow velocity is less than 3.1 m / s and more than 3.6 m / s[23]. This makes it easier for shrimp farmers to find out water quality and water flow in real-time and provide an efficient effect on time and energy. Based on this background, a monitoring system for water pH, water flow, and temperature based on the internet of things (IoT) will be designed using the ESP32 Module[24].

**II. METHODOLOGY**

System analysis and development consists of various activities that can be grouped into several stages that help researchers develop a system. The system development method used by researchers is Waterfall method[25]. The Waterfall method or waterfall is often called the classic life cycle, where it describes a systematic and sequential approach to software development, starting with the specification of user needs and then continuing through the stages of planning, modeling, construction, as well as delivery of the system to customers (deployment), which ends with support for the complete software produced[26],[27].

**A. Waterfall Method Stages**

The software development process (Software Development Process) is an application of a structure in the development of software (Software), which aims to develop the system and provide system guidance through certain stages[28].

Linear Sequential Model or Waterfall Development Model. The Linear Sequential Model, or the waterfall model, is the oldest and most widely used paradigm of software development models[29]. Proposes a software development approach starting at all stages of the analysis, design, code, testing, and implementation of the program[21].

In its development, the waterfall method has several sequential stages, namely:

**a) Requirement Analysis**

This stage of the system development required communication which aims to understand the software expected by users and the software limitations.

The author conducted a survey of the location of the shrimp farms and then conducted an interview process with the farmers to obtain information and data. The results of the interview can be seen in attachment 1 and attachment 2[19].

**b) System Design**

Requirements specifications from the previous stage will be studied in this phase, and the system design is prepared. After getting the results of interviews with shrimp farmers, the authors carry out the System Design stage, which is to determine the hardware (Hardware), software (Software), system requirements and define the overall system architecture[10].

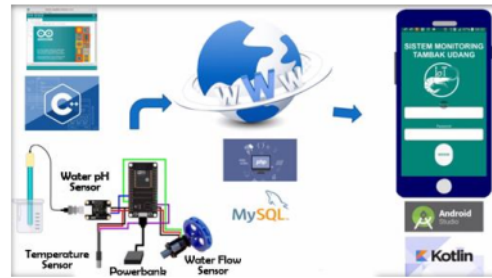

Figure 1 System design

**c) Implementation**

At this stage, the system is first developed in small programs called units, which are integrated into a later stage. Each hardware and software device is tested.



Figure 2 Application

**d) Testing**

All units developed in the implementation stage are integrated into the system after testing on both hardware and software. Then the author will monitor errors on each hardware and software device[30].



Figure 3 Testing

**e) Operation and Maintenance**

The final stage is the waterfall model. Hardware and software that have been finished run and carried out maintenance. Maintenance includes fixing errors that were not found in the previous step. Improved implementation of

system units and increased system services as new requirements.

**B.9 Context diagram**

Context Diagram is the highest level in the data flow diagram and contains only one process, showing the system as a whole [31]. The diagram contains no data storage and looks simple to create. The following is a context diagram of the shrimp pond monitoring system that will be made, and it can be seen in Figure 4.

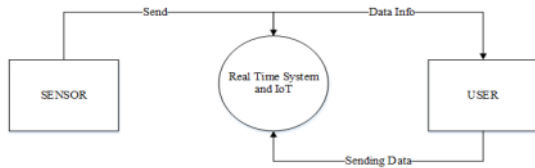

Figure 4 Context diagram of shrimp ponds

In the context diagram, the work system starts with a sensor that will send the data to the shrimp pond IoT system, then the information will be sent to the user, and the user will return to send data to the Real-Time System and IoT [32].

16

**C. Interface Design (User Interface)**

Interface Design (User Interface) is a means of developing a system that is used to make communication easier and more consistent between the system and its users. The emphasis of the interface includes a good interface, easy to understand and features that are familiar to the general public.

**Log in display design**

The design of this log in function is to find out who has the right to access the system and limit system usage. Users who can access this monitoring system are users who already have a Username and Password that have been registered in the database system. The following is the Log in display design in Figure 5.



Figure 5 Log in view

**Main display design**

The main display design is a display that will display data from the sensor. This display will display numbers and graphs according to the data obtained on the sensor. In this view there are icons to display bio data and icons to activate and deactivate warnings. The following is the main display design in Figure 6.



Figure 6 Main Display

**Notification display design**

In designing this notification display, it functions to display a warning when the condition of the sensors detects that there are advantages and disadvantages to the predetermined data. This display is an alarm and displays a warning form with the read conditions listed. The following is the notification display in Figure 7.



Figure 7 Notification Display

#### IV. RESULTS AND DISCUSSION

The discussion that will be carried out is to run, explain and test this IoT-based monitoring work system.

##### A. Hardware device

This discussion explains how the hardware device installation system is the water pH sensor PH-4502C, DS18B20 temperature sensor, and current sensor. Here's a look at the entire hardware.

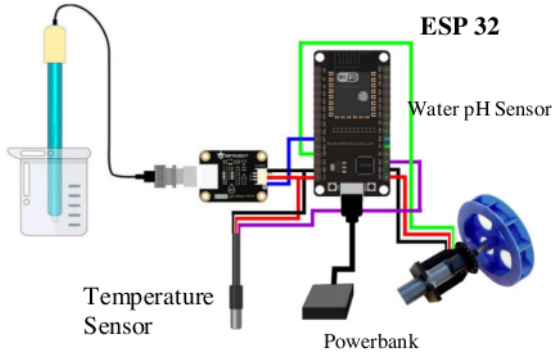

Figure 8 Hardware Sets

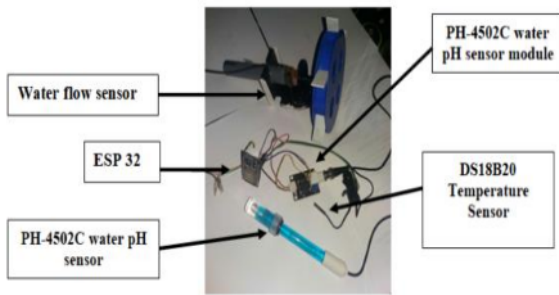

Figure 9 Hardware Device

##### Water pH sensor

In the installation of the PH-4502C water pH sensor, there are 3 cables, namely the blue cable as the jumpered input on pin D27 for the data transmitter to the ESP32 Module, the red cable for Vcc is the positive pole DC current flow input, which is jumpered to the Vcc 5V pin on the ESP32 Module, and the black cable is GND which is the ground used for the negative pole which is jumpered to the GND pin on the ESP32 Module. Here's a display of the series [33],[34].

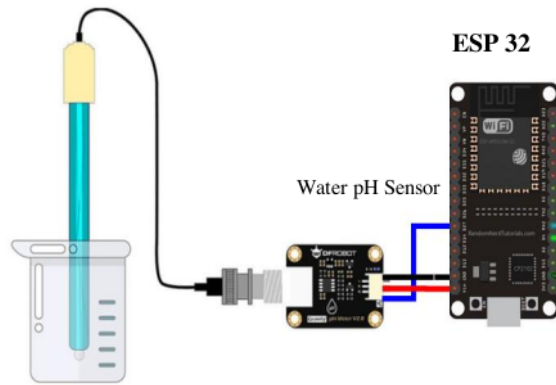

Figure 10 PH-4502C water pH sensor circuit



Figure 11 PH-4502C water pH sensor

##### DS18B20 Temperature Sensor

In the installation of the DS18B20 temperature sensor, there are 3 cables, namely the purple cable as the jumpered input on pin D14 which is useful for transmitting data to the ESP32 Module, the red cable is Vcc as a DC current flow which is a positive pole, then jumpered to the 5V Vcc pin on The ESP32 module, and the black cable is GND, which is the ground which is used as the negative pole which is jumpered to the GND pin on the ESP32 Module. Here's the form of the series [35],[36].

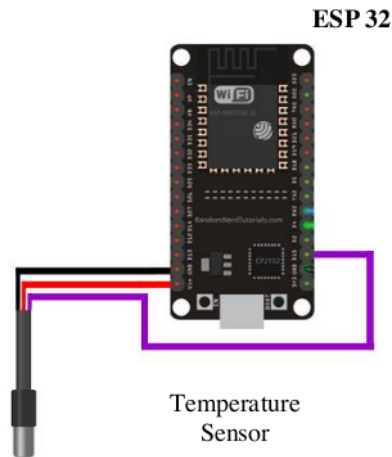

Figure 12 DS18B20 Temperature Sensor Circuit

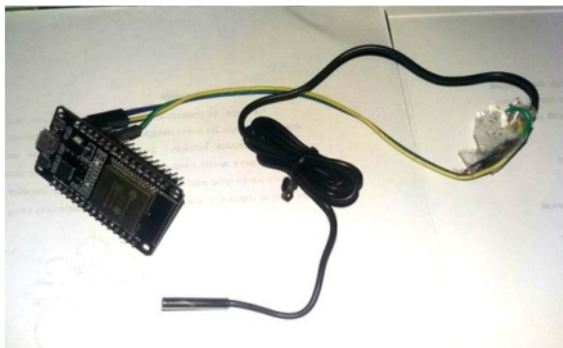

Figure 13 DS18B20 Temperature Sensor

**Water Flow Sensor**

In the current sensor installation, there are 3 cables, namely green as the input that is jumpered on pin D12 for the data transmitter to the ESP32 Module, and the red wire is Vcc as a positive pole DC current flow which is jumpered to the Vcc 3.3 V pin on the ESP32 Module and the cable is black is GND which is ground as a negative pole and then jumpered to the GND pin on the ESP32 Module. Here is the series [37],[38].

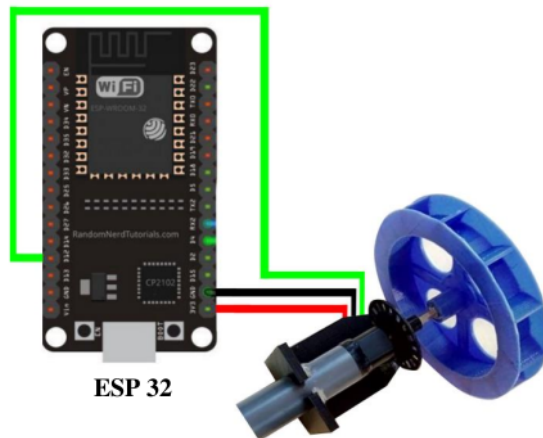

Figure 14 Water flow Sensor Circuit



Figure 15 Water flow Sensor

**B. Equipment Specifications**

This equipment specification describes in detail the results of tool design and material selection. The following is an overall view of the design of the tool in the shrimp pond location.



Figure 16 A look at the whole tool

**C. Main page (Real-Time System)**

On the main display, there are 3 graphs that display the results of the pH sensor readings of the PH-4502C water in red, the DS18B20 temperature sensor readings are blue, and the water current sensor readings are purple [39],[40]. Each graph displays hour, date, and month data. On the main display, there is a "bell" icon that functions as activating notifications and deactivating notifications. In the upper right corner, there is a "dot three" icon to display the biodata of the shrimp farm's owner.



**Figure 11. Main Page (Real-Time System)**

**D. Testing**

Testing is an important part of creating an IoT-based monitoring system[41]. Tests are carried out to determine the level of success, strengths and also to find out the weaknesses of the IoT-based Monitoring system that was created[42]. The following are the results of tests carried out in research on IoT-based monitoring systems.



**Figure 12 Testing process**

The method of testing is using the black box test method. The aim is to minimize errors during development and easily make improvements to system deficiencies that have been created.

**Hardware Testing**

**Table 1 Hardware Testing**

No	Sensor Name	Sensor	Measuring instrument	% error
1	Water pH Sensor	7.09	7.12	0.42 %
2	Water Flow Sensor	3.5 m/s	3.4 m/s	2.8 %
3	Temperature sensor	31°	30°	3.22 %

**Data results**

The results of the data were taken for 10 days in this study. The following are the results of the data obtained from the water pH, current, and temperature sensors. Details in Appendix 3.

**Table 2 Data results**

id	Shrimp farms	pH	temperature	Water flow	time
0001	Shrimp farms	07.08	30	03.05	10/07/2020 07.42
0002	Shrimp farms	07.09	29	03.05	10/07/2020 07.52
0003	Shrimp farms	07.09	30	03.04	10/07/2020 08.02
0004	Shrimp farms	07.08	29	03.03	10/07/2020 08.12
0005	Shrimp farms	07.06	29	03.05	10/07/2020 08.22
0006	Shrimp farms	07.09	29	03.05	10/07/2020 08.32
0007	Shrimp farms	07.09	28	03.04	10/07/2020 08.42
0008	Shrimp farms	07.08	29	03.03	10/07/2020 08.52
0009	Shrimp farms	07.06	29	03.05	10/07/2020 09.02
0010	Shrimp farms	07.09	29	03.05	10/07/2020 09.13
1440	Shrimp farms	07.09	28	03.05	20/07/2020 00.19

**3**

**E. System implementation**

System implementation is the system implementation stage that will be carried out if the system is approved, including programs that have been made at the system design stage so that it is ready for operation. This program is run using the Arduino IDE environment using the C ++ programming language, which is implemented in the ESP32 module. In this monitoring system, the ESP32 module will send monitoring data to a web-based online hosting server where the server component consists of PHP programming and the MySQL database server as a storage area for sensor monitoring [43]. And on the other hand, real-time monitoring will be carried out on the android platform using the android studio IDE with the Kotlin programming language, and this application will retrieve monitoring data from the server in real-time, which is displayed in graphical form and

notification alerts when water pH, temperature, and flow are unstable. This system is run using an android smartphone [44]-[50]-[51].

#### F. Scope of Implementation

Implementation limitations include things that must be considered before users want to run this monitoring system. The following are the implementation limitations

1. Users are required to understand using an Android smartphone.
2. The system created discusses the problem of monitoring shrimp ponds and notifications when there is the instability of data read by the sensor.
3. Required that shrimp farms have Wifi internet access.
4. It is recommended that only 1 person uses this monitoring system, namely the shrimp pond keeper.
5. In order for the sensor to work normally, the sensor cleaning process is carried out once a week.

#### G. Software Implementation

Software development in this monitoring system uses the C ++, PHP, Kotlin, and MySQL programming languages. The C ++ programming language is used by the ESP32 suite. The PHP programming language is used to manage the server. The Kotlin programming language is used to create applications on smartphones in the monitoring system. Meanwhile, MySQL is used to create data (database).

#### H. Hardware Implementation

Hardware is needed based on the needs that must be met, among others:

1. Using a core i5 processor or higher.
2. Using minimal 8 GB RAM.
3. Minimum smartphone Android 5 (lollipop)
4. Water flow sensor
5. PH sensor of water PH-4502C
6. DS18B20 Temperature Sensor
7. Module ESP32
8. Power bank

#### I. System maintenance

System Maintenance is a combination of various actions taken to keep a system in, or fix it to, an acceptable condition. The objectives of maintaining the system itself are:

1. Prevent system abnormalities that can lead to new problems.
2. Replace system maintenance with a system survey if the modifications requested are relatively large.
3. Prevent if the sensor device is damaged.

### V. CONCLUSIONS

Based on the tests that have been done, the authors conclude that: This monitoring system is based on IoT using a water pH sensor PH-4502C, DS18B20 temperature, and Flow, which will be processed using the ESP32 module. This monitoring system uses the internet to send data to sensors and will be displayed on a smartphone application. From the

measurement data of the water pH sensor compared to the results of the water pH meter, the results are minimal error, and the success rate has no error percentage (0.42%), the temperature sensor measurement data compared to the results of the temperature measurement tool has a percentage error (error) is 2.80%, while the current sensor measurement data compared to the results of the current measurement has an error percentage of 3.22%. From the results of data collection during the study, the average obtained on the ph of water is 7.8, the current sensor is 3.3 m / s, and the temperature sensor is 2.8 C °. From [17] research, the author can do his job to monitor water pH, water flow, and temperature.

### REFERENCES

- [1] Y. K. Taru and A. Karwankar, Water monitoring system using Arduino with Labview, International Conference on Computing Methodologies and Communication (ICCMC), Erode, (2017) 416-419.
- [2] M. Kumar Jha, R. Kumari Sah, M. S. Rashmitha, R. Sinha, B. Sujatha, and K. V. Suma, Smart Water Monitoring System for Real-Time Water Quality and Usage Monitoring, International Conference on Inventive Research in Computing Applications (ICIRCA), Coimbatore, (2018) 617-621
- [3] B. Das and P. C. Jain, Real-time water quality monitoring system using Internet of Things, International Conference on Computer, Communications, and Electronics (Comptelix), Jaipur, (2017) 78-82.
- [4] C. Sowmya, C. D. Naidu, R. P. Somineni and D. R. Reddy, Implementation of Wireless Sensor Network for Real-Time Overhead Tank Water Quality Monitoring, IEEE 7th International Advance Computing Conference (IACC), Hyderabad, (2017) 546-551
- [5] M. Simić, G. M. Stojanović, L. Manjakkal, and K. Zaraska, Multi-sensor system for remote environmental (air and water) quality monitoring, 2016 24th Telecommunications Forum (TELFOR), Belgrade, (2016) 1-4
- [6] Mohd Adli Ikram Shahrulakram and J. Johari, Water storage monitoring system with pH sensor for pharmaceutical plants, 6th International Conference on System Engineering and Technology (ICSET), Bandung, (2016) 46-52 DOI: <http://dx.doi.org/10.1109/ICSEngT.2016.7849621>.
- [7] I. Huang et al., The Prototype of a Smart Underwater Surveillance System for Shrimp Farming, 2018 IEEE International Conference on Advanced Manufacturing (ICAM), Yunlin, (2018) 177-180
- [8] C. Z. Myint, L. Gopal, and Y. L. Aung, Reconfigurable smart water quality monitoring system in IoT environment, 2017 IEEE/ACIS 16th International Conference on Computer and Information Science (ICIS), Wuhan, (2017) 435-440
- [9] K. Gopavanitha and S. Nagaraju, A low-cost system for real-time water quality monitoring and controlling using IoT, International Conference on Energy, Communication, Data Analytics and Soft Computing (ICECDS), Chennai, (2017) 3227-3229
- [10] Devis, Yesica, et al. Monitoring System of Heart Rate, Temperature and Infusion in Patients Based on Microcontroller (Arduino Uno). In: Journal of Physics: Conference Series. IOP Publishing, (2021) 012069.
- [11] Z. Lin, W. Wang, H. Yin, S. Jiang, G. Jiao and J. Yu., Design of Monitoring System for Rural Drinking Water Source Based on WSN, International Conference on Computer Network, Electronic and Automation (ICCNEA), Xi'an, (2017) 289-293 DOI: <http://dx.doi.org/10.1109/ICCNEA.2017.106>.
- [12] N. R. Moparthi, C. Mukesh and P. Vidya Sagar, Water Quality Monitoring System Using IOT, 2018 Fourth International Conference on Advances in Electrical, Electronics, Information, Communication, and Bio-Informatics (AEEICB), Chennai, (2018) 1-5
- [13] Latif, H. A. Widodo, R. A. Atmoko, T. N. Phong, and E. T. Helmy, Temperature and Humidity Controlling System for Baby Incubator, Journal of Robotics and Control (JRC), 2(3)(2021) 190-193.
- [14] N. H. Wijaya, Z. Oktaviahandani, K. Kunal, E. T. Helmy, and P. T. Nguyen, The Design of Tympani Thermometer Using Passive



- Infrared Sensor, *Journal of Robotics and Control (JRC)*, 1(1)(2020) 27–30.
- [15] EL BEQQAL, Mohamed; AZIZ, Mostafa. Taxonomy on IoT Technologies for Designing Smart Systems. *International Journal of Interactive Mobile Technologies (IJIM)*, (2018) 12.5 182-191.
- [16] EL MAHJOUBI, Ahmed; MAZRI, Tomader; HMINA, Nabil. NB-IoT and eMTC: Engineering results towards 5G/IoT Mobile Technologies. *International Journal of Interactive Mobile Technologies*, (2019) 13.1.
- [17] ALRIKABI, Haider Th, et al. The Application of Wireless Communication in IOT for Saving Electrical Energy. *International Journal of Interactive Mobile Technologies*, (2020) 14.1.
- [18] M. W. Hariyanto, A. H. Hendrawan, and R. Ritzkal Monitoring the Environmental Temperature of the Arduino Assistance Engineering Faculty Using Telegram, *Journal of Robotics and Control (JRC)*, 1(3)(2020) 96–101.
- [19] Yunardi, R. T., Arifianto, D., Bachtiar, F., & Prananingrum, J. I., Holonomic Implementation of Three Wheels Omnidirectional Mobile Robot using DC Motors. *Journal of Robotics and Control (JRC)*, 2(2)(2021) 65-71.
- [20] R. S. Kharisma and A. Setiyansah, Fire Early Warning Using Fire Sensors, Microcontroller, and SMS Gateway, *Journal of Robotics and Control (JRC)*, 2(3)(2021) 165–169.
- [21] T. P. Tunggal, L. A. Kirana, A. Z. Arfianto, E. T. Helmy, and F. Waseel, The Design of Tachometer Contact and Non-Contact Using Microcontroller, *Journal of Robotics and Control (JRC)*, 1(3)(2020) 65–69.
- [22] I. Prasojo, A. Maseleno, O. Tanane, and N. Shahu, Design of Automatic Watering System Based on Arduino, *Journal of Robotics and Control (JRC)*, 1(2)(2020) 55–58.
- [23] H. Li and X. Hua, Water Environment Monitoring System Based on Zigbee Technology, *Third International Conference on Intelligent System Design and Engineering Applications*, Hong Kong, (2013) 1607-1609  
DOI: <http://dx.doi.org/10.1109/ISDEA.2012.386>.
- [24] N. H. Wijaya, F. A. Fauzi, E. T. Helmy, P. T. Nguyen, and R. A. Atmoko, The Design of Heart Rate Detector and Body Temperature Measurement Device Using ATmega16, *Journal of Robotics and Control (JRC)*, 1(2)(2020) 40–43.
- [25] P. Megantoro, D. A. Husnan, M. U. Sattar, A. Maseleno, and O. Tanane, Validation Method for Digital Flow Meter for Fuel Vendors, *Journal of Robotics and Control (JRC)*, 1(2)(2020) 44–48.
- [26] Wijaya, N. H., Ibrahim, M., Shahu, N., & Sattar, M. U., Arduino-based Digital Advanced Audiometer. *Journal of Robotics and Control (JRC)*, 2(2)(2020) 83-87.
- [27] A. Hassan et al., A Wirelessly Controlled Robot-based Smart Irrigation System by Expliting Arduino, *Journal of Robotics and Control (JRC)*, 2(1)(2021) 29–34.
- [28] M. W. Hariyanto, A. H. Hendrawan, and R. Ritzkal Monitoring the Environmental Temperature of the Arduino Assistance Engineering Faculty Using Telegram, *Journal of Robotics and Control (JRC)*, 1(3)(2020) 96–101.
- [29] N. H. Wijaya, D. F. Novela, N. Shahu, and M. U. Sattar, Arduino-based Mini Shaker for Automatic Chemical Solution Mixer, *Journal of Robotics and Control (JRC)*, 1(6)(2020) 220–223.
- [30] Y. Al-Khashab, R. Daoud, M. Majeed, and M. Yasen, Drinking Water Monitoring in Mosul City Using IoT, *International Conference on Computing and Information Science and Technology and Their Applications (ICCISTA)*, Kirkuk, Iraq, (2019) 1-5
- [31] S. Syahrul and I. Komarujaman, Mixing and controlling the pH of citrate and phosphate with a website, *Journal of Robotics and Control (JRC)*, 2(4)(2021) 292–296.
- [32] N. H. Wijaya, W. A. Rijali, N. Shahu, I. Ahmad, and R. A. Atmoko, The Design of Electro Cardiograph Signal Generator Using IC 14521 and IC 14017, *Journal of Robotics and Control (JRC)*, 2(4)(2021) 270–273.
- [33] A. Wibisono, Wheeled Robot Design with Brain Wave Headset Control System, *Journal of Robotics and Control (JRC)*, 2(4)(2021) 322–327.
- [34] A. H. Noviyanto, L. D. Septilianingtyas, and D. Rahmawati, Design of a Continuous Passive Motion (CPM) Machine for Wrist Joint Therapy, *Journal of Robotics and Control (JRC)*, 2(4)(2021).
- [35] W. Robson, I. Ernawati, and C. Nugrahaeni, Design of Multisensor Automatic Fan Control System Using Sugeno Fuzzy Method, *Journal of Robotics and Control (JRC)*, 2(4) (2021) 302–306.
- [36] A. P. Atmaja, A. El-Hakim, A. P. A. Wibowo, and L. A. Pratama, Communication Systems of Smart Agriculture Based on Wireless Sensor Networks in IoT, *Journal of Robotics and Control (JRC)*, 2(4)(2021) 297–301.
- [37] I. M. A. Nugraha, I. G. M. N. Desnanjaya, I. W. D. Pranata, and W. Hariyanto, Stability Data Xbee S2b Zigbee Communication on Arduino Based Sumo Robot, *Journal of Robotics and Control (JRC)*, 2(3)(2021) 153–160, 2021.
- [38] W. Kartika, I. Santoso, and K. Supriyadi, Simple Wireless Nurse Call on Distance Measurement, *Journal of Robotics and Control (JRC)*, 2(3)(2021) 145–147.
- [39] N. H. Wijaya, B. A. Lesmana, N. Shahu, I. Ahmad, and R. A. Atmoko, Digital Embedding System with Heater and Cooler, *Journal of Robotics and Control (JRC)*, 2(3)(2021) 161–165 N.
- [40] D. Setiawan, I. Ishak, and M. A. Sembiring, Control System for Adjusting the Brightness Level with PWM Technique Using Visual Net Microcontroller-Based, *Journal of Robotics and Control (JRC)*, 1(4)(2020) 102–108.
- [41] M. Kesavan & M. Senthilkumar. Effect of Average Air Temperature and Relative Humidity on Global Radiation. *International Journal of Engineering Trends and Technology*, 67(3)(2019) 52-57.
- [42] M. Nirmala, Ch. Anoocha, D. Nagamani. Dynamic modeling of a GreenHouse using Arduino. *International Journal of Engineering Trends and Technology*, 68(2) 42-48.
- [43] Rahmani, W., & Wicaksono, A., Design, and implementation of a mobile robot for carbon monoxide monitoring. *Journal of Robotics and Control (JRC)*, 2(1)(2020) 1-6.
- [44] Loniza, E., Dhamayanti, D. C., & Safitri, M., Dehydration level detector through human urine with LED and LDR. *Journal of Robotics and Control (JRC)*, 2(3)(2021) 140-144.
- [45] Beltran Jr, A., Dizon, K. J., Nones, K., Salanguit, R. L., Santos, J. B., & Santos, J. R., Arduino-based Disaster Management System. *Journal of Robotics and Control (JRC)*, 2(1)(2021) 24-28.
- [46] A. Firdausi and G. P. N. Hakim., RSSI Indoor Outdoor Personal Localization: A Study to Found Targeted Social Engineering Victim by Attacker Via Wireless Methods, *Journal of Robotics and Control (JRC)*, 2(4)(2021) 328–331.
- [47] Prasojo, I., Maseleno, A., & Shahu, N., The Design of Earthquake Detector Using Pendulum Swing Based on ATmega328. *Journal of Robotics and Control (JRC)*, 2(3) (2021) 209-211.
- [48] Handaya, D., & Fauziah, R., Proportional-Integral-Derivative and Linear Quadratic Regulator Control of Direct Current Motor Position using Multi-Tum Based on LabView. *Journal of Robotics and Control (JRC)*, 2(4)(2021) 332-336.
- [49] S. Sinha, U. Srivastava, V. Dhiman, A. P.S, and S. Mishra, Performance assessment of Deep Learning procedures on Malaria dataset, *Journal of Robotics and Control (JRC)*, vol. 2(1)(2021) 12–18.
- [50] Irawan, Y., Linarta, A., & Febriani, A., Smart Home Light-Based Service Oriented Architecture and IoT. In *Journal of Physics: Conference Series* 1845(1)(2021) 012070. IOP Publishing.
- [51] M. V. S. Rao and M. Shivakumar, IR Based Auto-Recharging System for Autonomous Mobile Robot, *Journal of Robotics and Control (JRC)*, 2(4)(2021) 244–251.

# Turnitin

## ORIGINALITY REPORT

12%

SIMILARITY INDEX

7%

INTERNET SOURCES

8%

PUBLICATIONS

7%

STUDENT PAPERS

## PRIMARY SOURCES

- 1 Submitted to Asia Pacific University College of Technology and Innovation (UCTI) 2%

Student Paper
- 2 [ojs.stmikpringsewu.ac.id](https://ojs.stmikpringsewu.ac.id) 2%

Internet Source
- 3 R. Gilang Fauzi Yusuf, Lia Kamelia, Eki Ahmad Zaki hamidi, Ulfiah. "The Monitoring System Prototype Of Health Condition For Home Care Patients Base On the Internet Of Things", 2020 6th International Conference on Wireless and Telematics (ICWT), 2020 1%

Publication
- 4 Fadhliati Fadhliati. "Designing a Website Based Aceh Translation Application Using Rule-Based", International Journal Education and Computer Studies (IJECS), 2021 1%

Publication
- 5 [tsukuba.repo.nii.ac.jp](https://tsukuba.repo.nii.ac.jp) 1%

Internet Source
- 6 Hetty Ismainar, Rika Melyanti, Yulisman, Suandi Daulay, Yuda Irawan, Rian Ordila. 1%

"Management Information System for Lancang Kuning Hospital Dompot Dhuafa Pekanbaru Using Codeigniter Framework",  
Journal of Physics: Conference Series, 2021  
Publication

---

7 emitter2.pens.ac.id 1 %  
Internet Source

---

8 Submitted to UIN Sunan Kalijaga Yogyakarta 1 %  
Student Paper

---

9 www.docstoc.com 1 %  
Internet Source

---

10 Yuda Irawan, Chrismondari, Yolnasdi, Ari Linarta, Muhardi, Anita Febriani. "Smart Home Light Based Service Oriented Architecture and IoT", Journal of Physics: Conference Series, 2021 <1 %  
Publication

---

11 Anh Duc Le, Quoc B Nguyen, Ngoc Chat Tran, Ngoc Hung Nguyen. "A remote-controlled detector system with Geiger-Müller counter", Physics Education, 2021 <1 %  
Publication

---

12 Submitted to President University <1 %  
Student Paper

---

13 Submitted to Cornell University <1 %  
Student Paper

---

- 
- 14 [eudl.eu](http://eudl.eu) Internet Source <1 %
- 
- 15 Yesica Devis, Yuda Irawan, Junadhi, Fransiskus Zoromi, Herianto, Mohd Rinaldi Amarta. "Monitoring System of Heart Rate, Temperature and Infusion in Patients Based on Microcontroller (Arduino Uno)", Journal of Physics: Conference Series, 2021  
Publication <1 %
- 
- 16 [www.warse.org](http://www.warse.org) Internet Source <1 %
- 
- 17 [www.bosch-climate.com.au](http://www.bosch-climate.com.au) Internet Source <1 %
- 
- 18 Nurhening Yuniarti, Didik Hariyanto, Sigit Yatmono, Muchlis Abdillah. "Design and Development of IoT Based Water Flow Monitoring for Pico Hydro Power Plant", International Journal of Interactive Mobile Technologies (ijIM), 2021  
Publication <1 %
- 

Exclude quotes Off

Exclude matches Off

Exclude bibliography On